

AMX-3981

3G/HD/SD 8 AES

Audio and Metadata Embedder

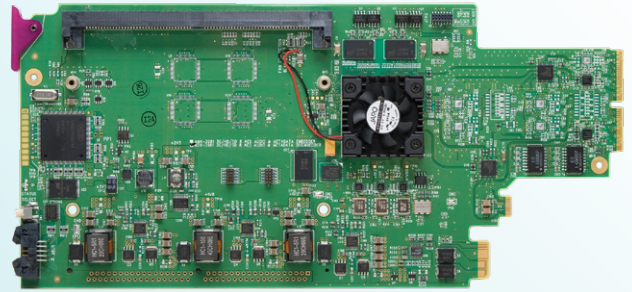

Space-saving, modular platform for advanced signal processing.

The AMX-3981 from Grass Valley[®] is an advanced, high-quality audio processor which embeds up to eight (8) AES signals into a 3G/HD/SD video signal. Each AES input can accept different sample rates, or even asynchronous audio, and will be resampled at 48 kHz by a sample rate converter, which can be manually or automatically disabled in the presence of non-PCM audio.

The AMX-3981 can simultaneously process up to 32 channels of audio (16 channels from the discrete AES inputs, and 16 channels of embedded audio). Functions include downmixing, proc amp, channel shuffling, mixing and loudness measurement..

The loudness measurement function allows the measurement and logging of up to four audio programs with iControl[™] loudness monitoring software to analyze and report compliance with respect to various loudness regulations around the world.

The AMX-3981 has one on-board socket for optional modules, which can offer Dolby decoding, Dolby

encoding and stereo upmixing using Linear Acoustic upMAX technology. One other module provides ALC using AEROMAX technology by Linear Acoustic, capable of maintaining constant loudness across different audio programs.

The card will pass and delay automatically all 32 internal audio channels to preserve lip sync between the channels. Each channel can be delayed independently to correct any lip sync issues. All audio channels can be mixed and shuffled to provide 16 channels for embedding in the video output.

An automatic preset recall feature provides basic automation to select user preset based on the status of the incoming audio.

When genlocked to the frame reference using the internal URS signal, the AMX-3981 can handle video hot switches at the input without losing sync at the output. In the absence of a video input, the card can still output synchronous video and embed the discrete AES audio.

The card has a frame buffer (not a frame sync) which allows an increase in the video delay of up to 15 frames to compensate for the long audio processing delay required by some modules. For applications which require a small processing delay, the frame buffer can be bypassed to reduce the delay to a few microseconds.

The AMX-3981 can embed linear timecode (LTC) as ancillary timecode (ATC) in 3G/HD and DVITC in SD. Up to three GPIO can be used as input or output to embed or extract GPI events to/from the timecode user bits in transport applications. They can also be used simultaneously to trigger the card's user presets.

Dolby metadata insertion in the VANC is possible from multiple sources, such as a Dolby E decoder module, an embedded VANC stream, an external RS-422 link, or from the integrated metadata generator. All parameters in the metadata stream can be probed and monitored. Dolby metadata can be used to steer the behavior of the audio downmix and upmix modules.

A fiber input/output cartridge is offered as an option on some rear modules. Once the cartridge is installed, the inputs or outputs are selectable through the control interface. The input of the card allows you to select between fiber and copper inputs. The outputs are

via copper and fiber simultaneously (with appropriate fiber cartridge).

There are many benefits to the AMX-3981's high level of feature integration. A lower purchase cost per channel is obviously highly desirable but there are many other dimensions to cost savings that are

readily achievable. These include reduced space and cooling costs, less cabling, and a reduced spares inventory. By simplifying video and audio synchronization, and reducing the number of vendors, the system integration is also simplified significantly.

Key Features

Video

- 3G/HD/SD input
- Supports 3 Gb/s level A (mapping 1) and level B
- Audio/video de-glitcher to handle video hot switch at the input
- Automatic detection of input video loss and switchover to local black for continuity of embedded audio
- Flexible HD/SD reference using the internal URS frame reference
- Minimum processing delay of 8 μ s, but additional delay can be added up to 15 frames
- Optional optical fiber module

Metadata

- AFD (SMPTE ST 2016), VLI (RP-186) and WSS insertion
- Linear timecode (LTC) embedding into DVITC (SD) or ATC (3G/HD)

- Audio metadata insertion and extraction (SMPTE ST 2020-A)
- RS-422 serial data input/output to carry audio metadata
- 3 GPI inputs/outputs that can be inserted or extracted in the TC user bits. They can also be used for automation, user preset recall and loudness reset

Audio

- 8 AES inputs
- Sample rate conversion for asynchronous AES inputs
- Full audio shuffling and mixing on a channel basis
- 32 channels internal audio processing
- Automation capabilities based on audio signal type detection
- Audio 5.1 surround downmix to Lt/Rt or Lo/Ro

- Audio delay adjustments of up to ± 2 seconds to compensate for lip sync issues
- Loudness measurement of up to ± 4 audio programs and logging with iControl loudness monitoring option
- Loudness compliant to EBU R128-2014, ATSC A/85:2013 (FCC CALM compliant) and ARIB TR-B32 (ITU-R BS.1770-3)
- On-board socket for 1 optional module expansion:
 - Dolby E and Dolby Digital decoder
 - Dolby Digital and Dolby Digital Plus encoder
 - Dolby E encoder
 - Linear Acoustic upMAX
 - Linear Acoustic AEROMAX automatic loudness control

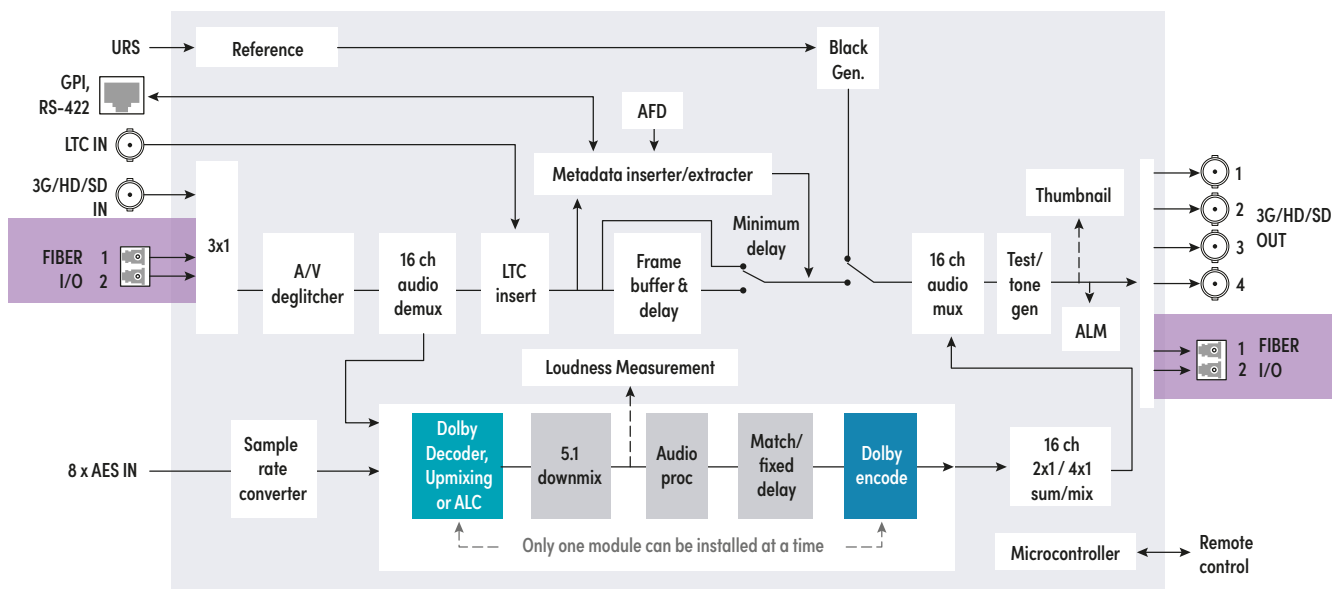

AMX-3981 Functional Block Diagram

Options (hardware & software)			
	With appropriate fiber cartridge & -F rear module		MOD-DOLBY-ENC-E-2
			MOD-DOLBY-ENC-D-2
			MOD-LA-ALC
			MOD-LA-DUP-701
			MOD-DOLBY-DEC-2

Specifications

Video Input/Output

Signal (1):

- SMPTE ST 259-C (270 Mb/s)
- SMPTE ST 292 (1.485, 1.485/1.001 Gb/s)
- SMPTE ST 424 (2.970, 2.970/1.001 Gb/s)

Supported formats:

- SD: 480i59.94, 576i50
- HD: SMPTE ST 274: 1080i59.94, 1080i50
- HD: SMPTE ST 296: 720p59.94, 720p50
- 3G: SMPTE ST 425 level A (mapping 1), level B: 1080p59.94, 1080p50

Cable length:

- 300m (984 ft.) Belden 1694A at 270 Mb/s
- 150m (492 ft.) Belden 1694A at 1.485 Gb/s
- 120m (393 ft.) Belden 1694A at 2.970 Gb/s

Return loss: >15 dB up to 3 GHz

Jitter:

- HD/SD: <0.2 UI
- 3G: <0.3 UI

Audio Input (8)

Sampling freq.: 32 to 96 kHz

Quantization: up to 24 bits

AES3

- Level: 0.2 to 7 Vp-p
- Impedance: 110Ω balanced

AES3-id

- Level: 0.2 to 2 Vp-p
- Impedance: 75Ω

Return loss: 15 dB at 6 MHz

Reference Input

Signal (1): Through the URS internal frame reference signal

Optical

Signal: Refer to SFP module specifications

LTC

Signal (1): SMPTE ST 12

Connector: RJ45 (-3SRP rear), BNC (-3DRP rear)

Impedance: <10 kΩ (bridging 600Ω) unbalanced

Level: 0.3 to 5 Vp-p

GPIO (-3DRP Rear)

Signal (3): Contact closure to ground

Direction: Bidirectional (application specific)

GPIO (-3SRP Rear)

Signal (2): Contact closure to ground

Direction: Bidirectional (application specific)

RS-422

Signal (2): RS-422

Input level: 300 mVp-p (min)

Output level: 3 Vp-p (min)

Rate: 115, 200 Bd

Video Processing Performance

Signal path: 10 bits

Processing delay (HD): 8 μs (in minimum delay mode)

Additional delay: Up to 15 frames upon user selection

Audio Processing Performance

Quantization: 24 bits

Sampling: 48 kHz, synchronous

Audio latency: 2 to 6 ms in minimum processing delay depending on processing options

Audio delay: Up to 2s (1 ms steps)

Electrical

Power: 12.5W



Ordering

Densité® 3 frame

Model	Description
AMX-3981	3G/HD/SD 8 AES audio and Metadata embedder
AMX-3981-75D-3SRP	Single rear connector panel, 75Ω Din 1.0/2.3
AMX-3981-110-3SRP	Single rear connector panel, 110Ω
AMX-3981-75-3DRP-F	Double rear connector panel, 75Ω and fiber connector
AMX-3981-110-3DRP-F	Double rear connector panel, 110Ω and fiber connector

Options (Hardware)

SFP-RR-LC	Dual fiber RX (input) cartridge with LC/PC connector
SFP-TT-S13S13-LC	Dual fiber TX (output) cartridge at 1310 nm with LC/PC connector
SFP-R-LC	Single fiber RX (input) cartridge with LC/PC connector
SFP-T-S13-LC	Single fiber TX (output) cartridge at 1310 nm with LC/PC connector
SFP-RT-S13-LC	Single fiber RX (input) and TX (output) cartridge at 1310 nm with LC/PC connector

Other types of SFP Optical Plug-In Cartridges may be available for this product.

NSH15M	HD-15 to terminal block adapter
NSH26M	HD-26 to terminal block adapter
MOD-DOLBY-ENC-E-2	Dolby E encoder
MOD-DOLBY-ENC-D-2	Dolby Digital (AC-3) encoder
MOD-DOLBY-DEC-2	Dolby E and Digital (AC-3) decoder
MOD-LA-DUP-701	Upmixing using Linear Acoustic Technology upMAX
MOD-LA-ALC-2	2-channel ALC licensed by Linear Acoustic
MOD-LA-ALC-6	6-channel ALC licensed by Linear Acoustic
MOD-LA-ALC-8	8-channel ALC licensed by Linear Acoustic
MOD-LA-ALC-2-DUP	2-channel ALC and upmix licensed by Linear Acoustic
MOD-LA-ALC-6-DUP	6-channel ALC and upmix licensed by Linear Acoustic
MOD-LA-ALC-8-DUP	8-channel ALC and upmix licensed by Linear Acoustic
Remote control	GV Orbit, iControl, iControl Solo

This product may be protected by one or more patents. For further information, please visit: www.grassvalley.com/patents

DS-PUB-3-0347A-EN

Grass Valley®, GV® and the Grass Valley logo are trademarks or registered trademarks of Grass Valley USA, LLC, or its affiliated companies in the United States and other jurisdictions. Grass Valley products listed above are trademarks or registered trademarks of Grass Valley USA, LLC or its affiliated companies, and other parties may also have trademark rights in other terms used herein. Copyright © 2020, 2023 Grass Valley Canada. All rights reserved. Specifications subject to change without notice.

www.grassvalley.com Join the Conversation at GrassValleyLive on [Facebook](#), [Twitter](#), [YouTube](#) and Grass Valley on [LinkedIn](#)