

DATASHEET

# AUTOMATIC LOUDNESS CONTROL (ALC)

## Advanced Loudness Control Solutions Which Prevent Excessive Audio Jumps

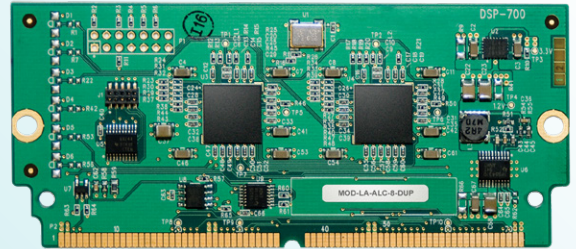

Space-saving, modular platform for advanced signal processing.

Excessive loudness variation is probably the most common viewer complaint, and it's now something you can eliminate entirely. Our automatic loudness control solutions for our Densité® interfaces are designed to address all typical loudness problems, including audio jumps between programs and commercials, without adversely impacting the program content.

Uniquely, Grass Valley® offers two distinct automatic loudness control solutions which bring together the very best loudness technology:

- ALC with Linear Acoustic AEROMAX processing
- ALC with Grass Valley wideband audio processing

Both solutions can be used effectively to address loudness problems across multiple applications, such as broadcast playout, server ingest, production and post-production. However, the best fit solution will depend on an individual facility's particular channel mix and program dynamics, as well as the associated playout workflow and equipment.

### ALC Solutions Overview

#### ALC with Linear Acoustic Aeromax Processing

- Advanced loudness control, using proven Linear Acoustic AEROMAX multiband audio processing
- Highly flexible processing, with excellent performance with vocal tracks
- Up to 8 channels of loudness processing per submodule
- Audio processing for up to 2 programs per submodule (mono, stereo, 5.1 audio)
- Optional 2.0 to 5.1 upmixing using Linear Acoustic technology

#### ALC with Grass Valley Wideband Audio Processing

- Lower cost, high-performance wideband audio processing
- Designed for easy configuration and control
- Up to 16 channels of on-board loudness processing
- Audio processing for up to 8 programs (mono, stereo, 5.1 or 7.1 audio)
- Firmware based solution leaves the submodule sockets on the host card free for other advanced processing functions
- Now supporting loudness measurements and true-peak limiter according to ITU-R BS.1770-3



This ALC option uses a submodule mounted on a Densité card

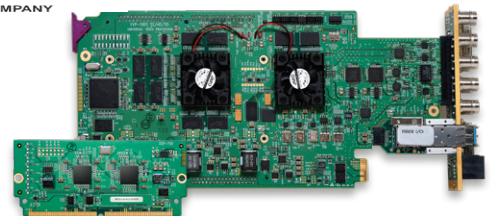

This ALC option uses a firmware upgrade for a Densité card



## Key Features

- Automatic loudness control option for Densité interfaces smooths out irritating loudness level differences between program segments and between different channels
- High-quality processing prevents adverse effects to program content
- Three different processing variants allow selection to best match a facility's content and workflow
- Multiband or wideband processing
- Up to 16 audio channels processing capacity
- Multiprogram support using mono, stereo, 5.1 or 7.1 audio
- "Set and forget" mode with setting of output target loudness per program
- Actively managed processing modes, with playout automation driving a bypass mode or different profiles
- Loudness monitoring according to ITU-R BS.1770
- Upmixing can be combined with ALC for optimal integration (Linear Acoustic)
- Manual remote control by GV Orbit®, iControl™ or iControl Solo PC GUI
- Now supporting loudness measurement and true-peak limiter according to ITU-R BS.1770-3

## Automatic Loudness Control Using Linear Acoustic AEROMAX

Advanced loudness control is offered by ALC with Linear Acoustic AEROMAX audio processing. It uses a third-generation audio processor to provide a simple and cost-effective solution for guarding against loudness shifts.

### Multiband Architecture

The AEROMAX algorithms use a multiband approach to loudness control. These algorithms can apply multiband,

multistage loudness control to the audio, resulting in audio free from abrupt loudness or image shifts, while preserving more of the original content than previously possible.

This version of ALC can be packaged with, or without, the Linear Acoustic upMAX upmixer on the same submodule for optimal integration.

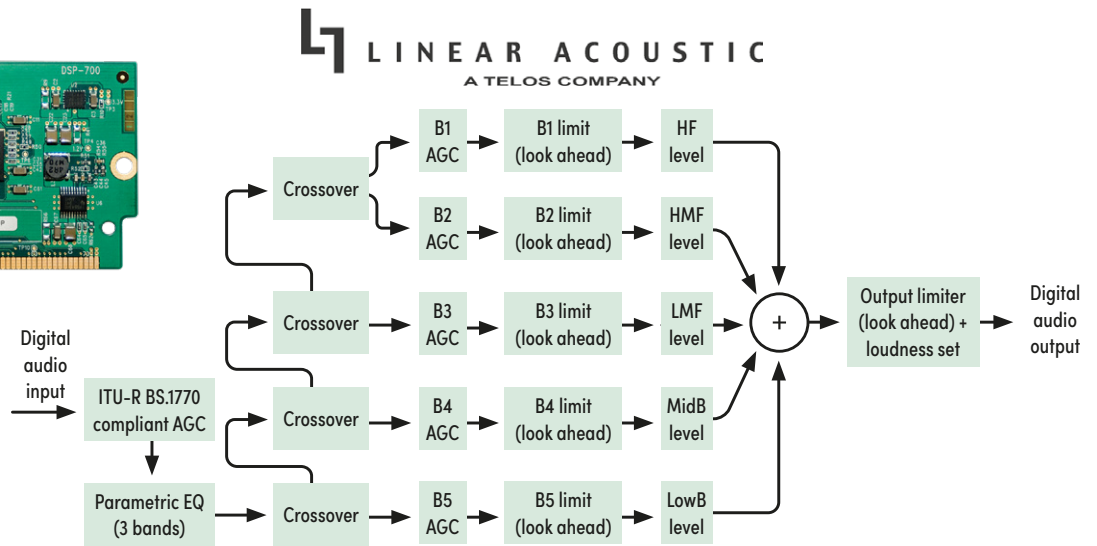
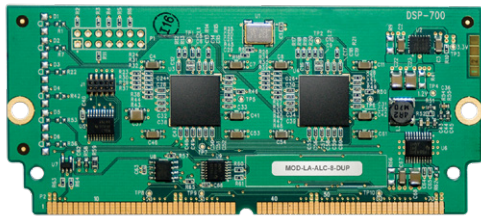

### Typical program configurations using AEROMAX

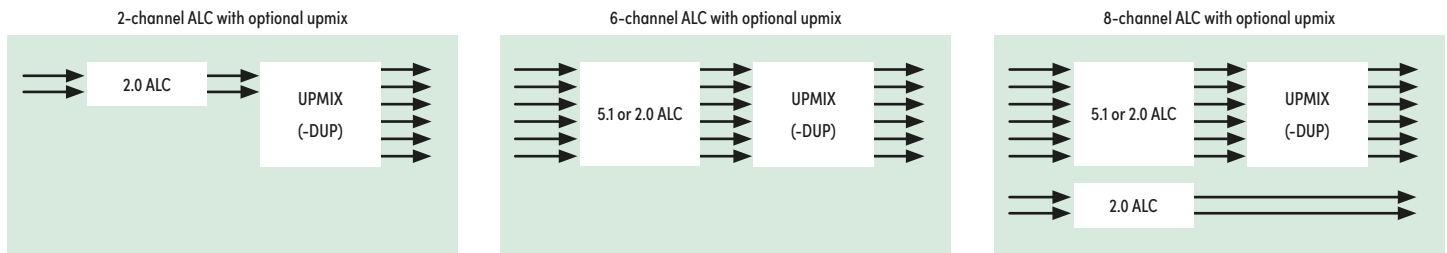

Upmixing is only available with the -DUP ordering codes.

Other channel configurations are also supported. Please visit [www.grassvalley.com](http://www.grassvalley.com) for more information.

## Specifications

**Architecture:** 8 channel multiband (5) processing  
**Number of programs:** 1 or 2  
**Program configuration:** 2 and/or 6 audio channels

**Loudness measurement:** ITU-R BS.1770  
**Sampling:** Up to 24 bits at 48 kHz  
**Processing profiles:** 6

**Limiter set range:** -6 to 0 dBFS or  $\pm 6$  dB  
**AGC pulling range:**  $\pm 36$  dB

## Ordering

<b>MOD-LA-ALC-2</b>	2-channel ALC licensed by Linear Acoustic
<b>MOD-LA-ALC-6</b>	6-channel ALC licensed by Linear Acoustic
<b>MOD-LA-ALC-8</b>	8-channel ALC licensed by Linear Acoustic
<b>MOD-LA-ALC-2-DUP</b>	2-channel ALC and up mix licensed by Linear Acoustic
<b>MOD-LA-ALC-6-DUP</b>	6-channel ALC and up mix licensed by Linear Acoustic
<b>MOD-LA-ALC-8-DUP</b>	8-channel ALC and up mix licensed by Linear Acoustic

## ALC with Grass Valley Wideband Audio Processing

Lower cost, high-performance loudness control is provided by ALC using Grass Valley's proprietary wideband audio processing algorithms. This variant of ALC offers versatile, easily configured loudness processing, which does not adversely affect the program content.

### Wideband Architecture

This ALC option uses a firmware upgrade to the hosting card. Up to eight different programs and up to 16 channels can be processed simultaneously, with independent controls and loudness meters on each program. This ALC variant leaves the submodule sockets on the host card free for other advanced processing functions.

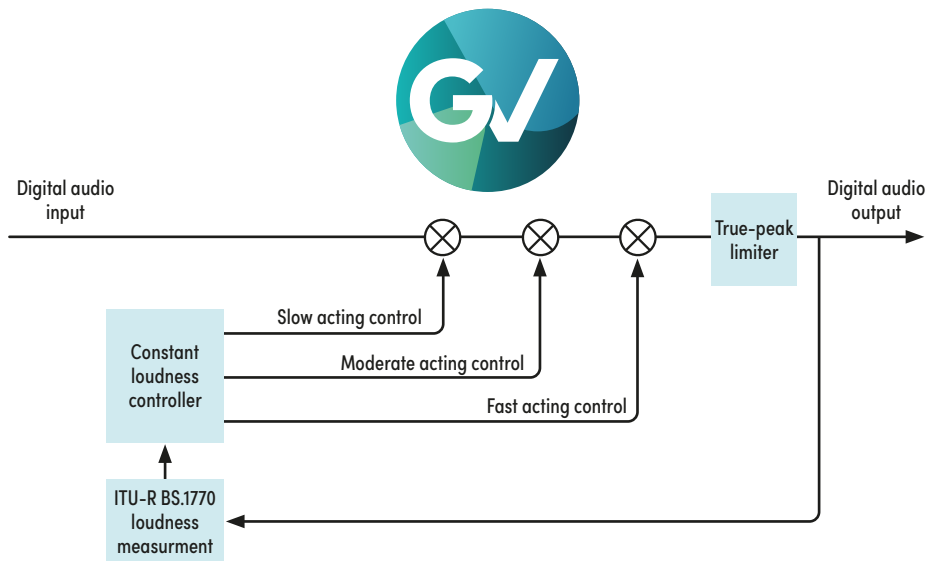

### Typical configurations

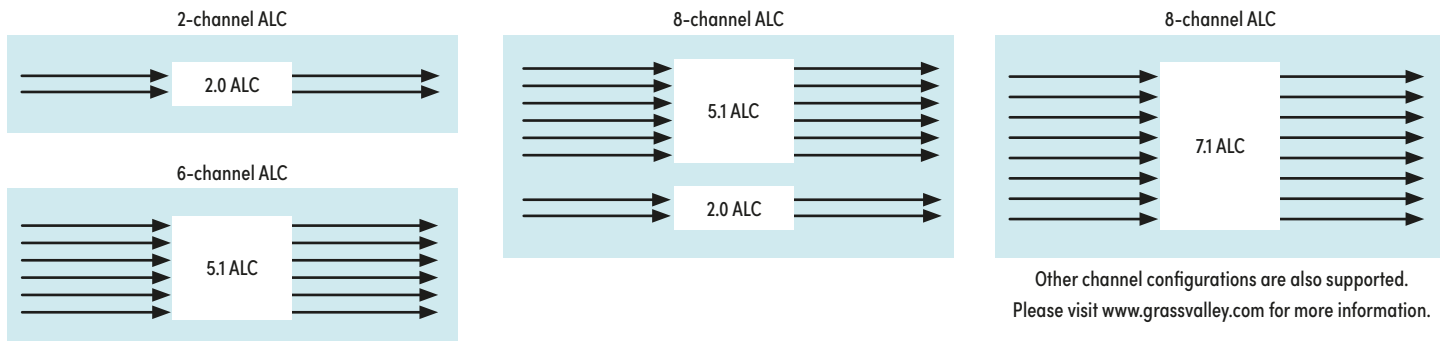

## Specifications

**Architecture:** 16 channel wideband processing  
**Number of programs:** Up to 8  
**Program configuration:** 1, 2, 3, 4, 6 or 8 audio channels

**Loudness measurement:** ITU-R BS.1770-3  
**Sampling:** Up to 24 bits at 48 kHz  
**Processing profiles:** 3/5  
**Target loudness range:** -31 to -10 LKFS

**Limiter set range:** -20 to dBFS true-peak  
**AGC pulling range:** -31 to +18 dB  
**Pre-gain stage range:** -20 to 20 dB

## Segment-to-Segment: Active Loudness Control



Grass Valley’s ALC solutions can be operated in a “set-and forget” mode, with the setting of an output Target Loudness per program. This mode can achieve excellent results, and the performance can be optimized by selecting a loudness processing profile that best matches the content of the facility.

An alternative approach to loudness processing involves using playout automation to actively control

the loudness processing profile, according to the type of content. This can yield improved results when the facility uses a significant amount of programming with a controlled loudness level or a reliable Dialnorm value.

In the example below, a facility controls three different profiles by playout automation to create an optimal loudness processing result, with minimal impact to the original

program dynamics. The three different profiles provide aggressive loudness control for commercials, light processing for a movie with an uncontrolled loudness level, and a complete bypass of the ALC processing for a program with the correct loudness level or a reliable Dialnorm value. Traditionally, the most problematic content from a loudness control perspective has been commercial and promo insertions.

	Program	Promo	Movie
			
Program Segments	Program with correct loudness level or reliable Dialnorm value	Loud promo	Movie with uncontrolled loudness level
Automation Decisions	ALC is bypassed	ALC is engaged with an aggressive profile	ALC is engaged with a light profile
Effects on Original Audio	Audio remains intact with its original dynamics while the program meets station’s target loudness	Audio level matches target loudness but compression will likely affect original dynamics	Audio level matches target loudness with a slight impact on the original film audio dynamics

Active Control of ALC by Playout Automation

## Headend Uses Decoding, ALC Audio Processing, and Re-encoding

Can fix both channel-to-channel and segment-to-segment loudness problems.

*Note:* This configuration is possible if the audio compression algorithm and the bit rate in use allow for an extra

generation of encoding without creating audible artifacts when decoded at final destination.

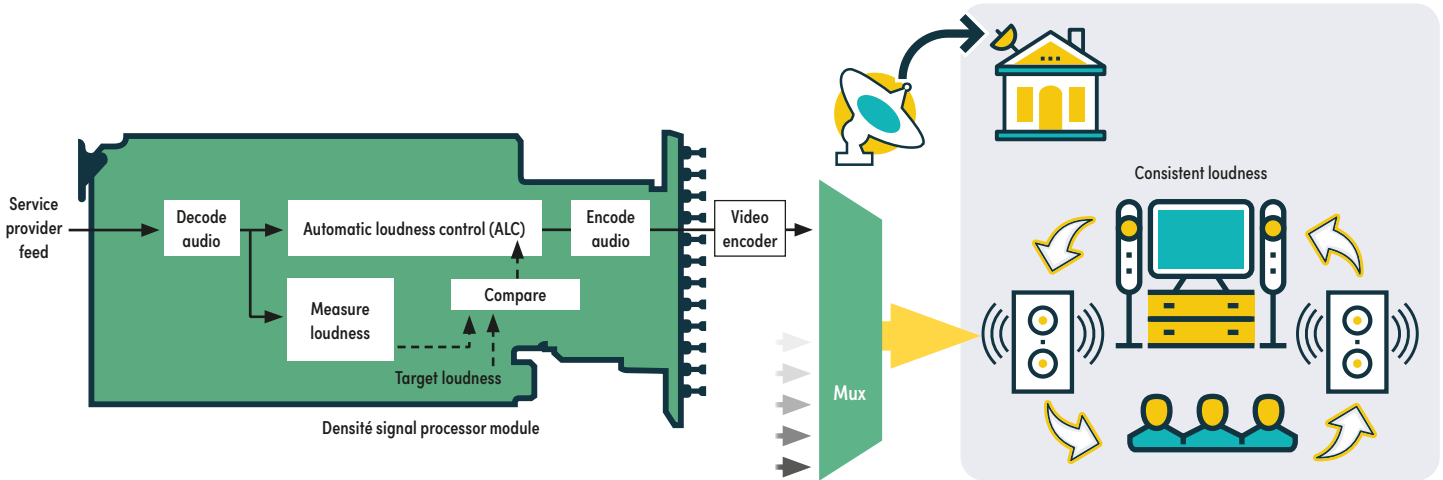

*Note:* This configuration is possible if the audio compression algorithm and the bit rate in use allow for an extra generation of encoding without creating audible artifacts when decoded at final destination.

## Playout using “set and forget” mode with ALC

- Output target loudness is maintained by ALC
- Loudness control can be optimized by choosing an ALC profile that best matches the facility’s content

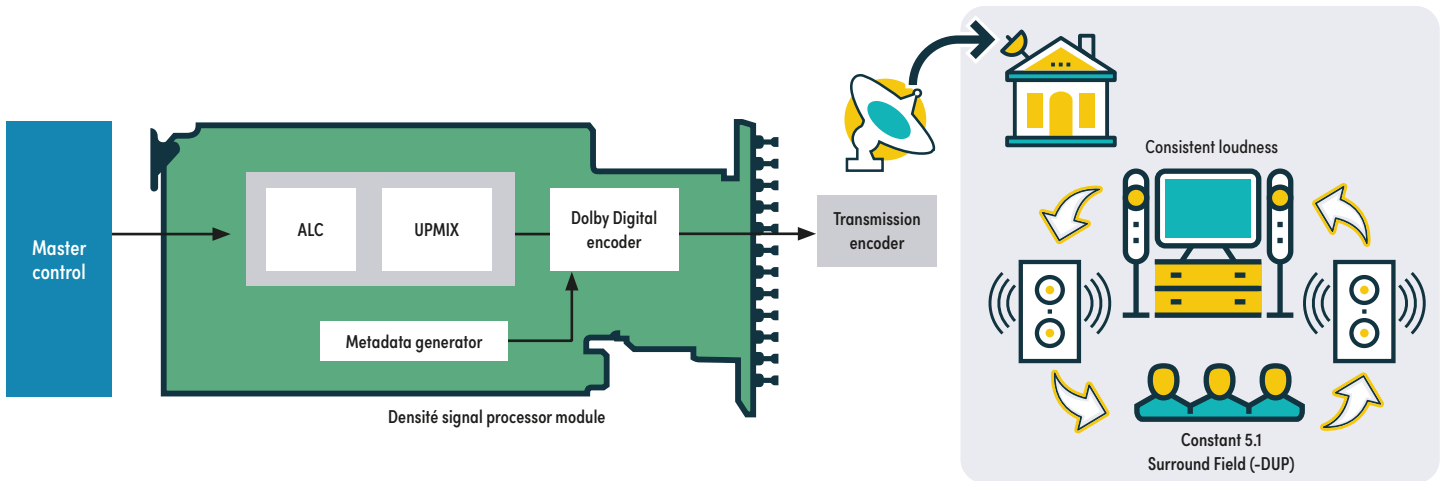

## Playout using active control of ALC by automation system

- Automation triggers different ALC profiles according to the program content, driven by content tagging performed by the traffic team
- By adapting the ALC profiles to the content, there is minimal impact to original program dynamics

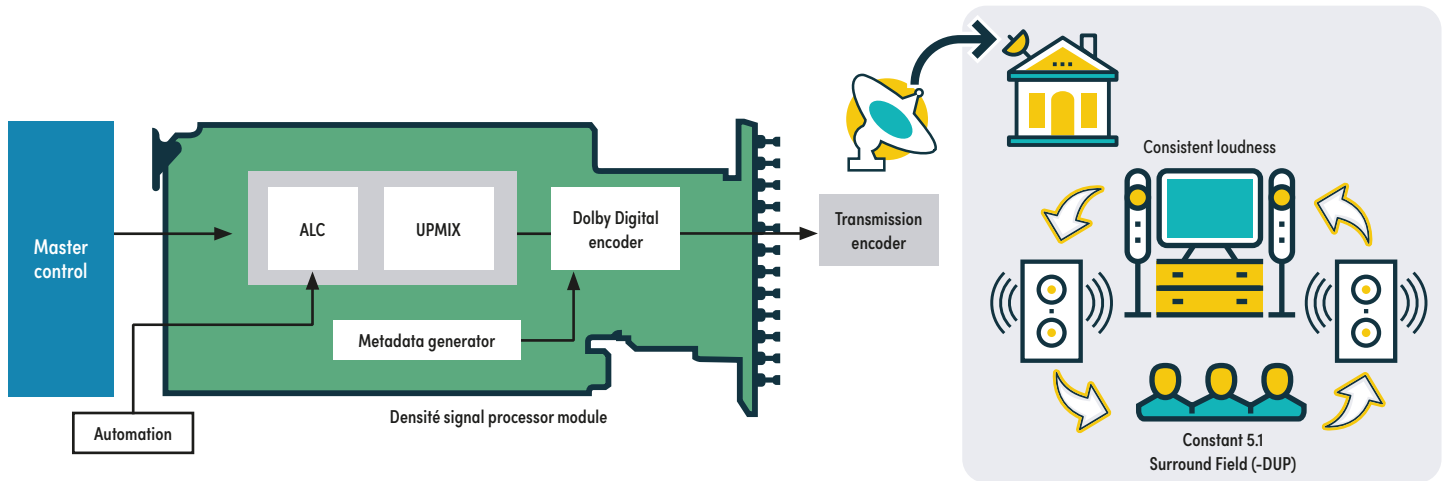

## Dolby Decode/ALC at ingest

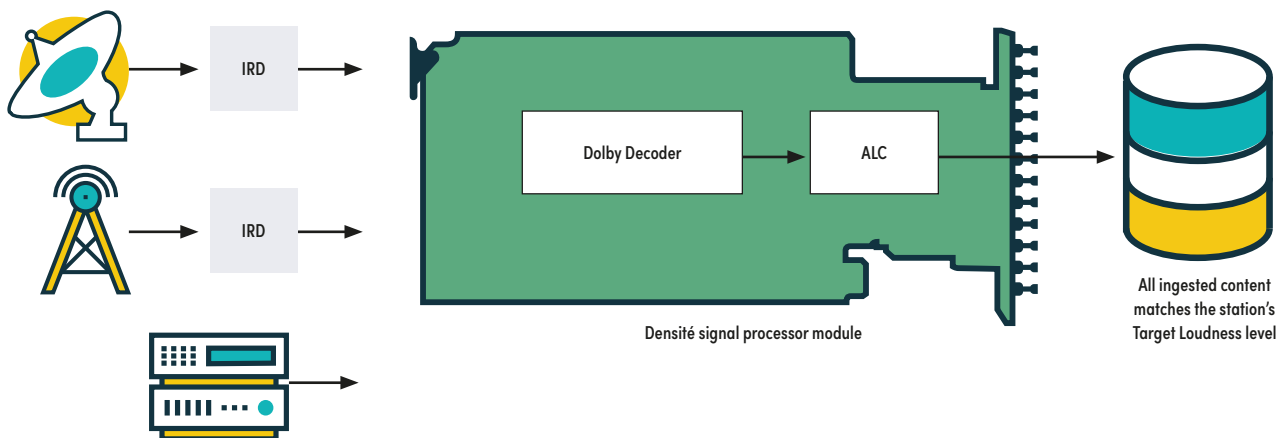

## Channel-to-Channel Loudness Control: ALC at Head-ends

Channel-to-channel loudness inconsistencies are another key issue, especially for cable and IPTV service providers. It's common for viewers to experience different loudness levels as they switch between channels, and this is because the channels will have different average loudness and inconsistent Dialnorm values.

Often, the cause of this channel-to-channel loudness variation is the broadcaster's use of a default -27 dB Dialnorm value for the Dolby Digital encoder when there is significant variation in the average loudness of the program segments.

Fortunately, Grass Valley's automatic loudness control solutions can be used to address the problem by decoding and processing the audio with ALC, and then re-encoding. The Densité signal processor card can re-stamp a consistent Dialnorm value to match the target loudness value used by the ALC processor.

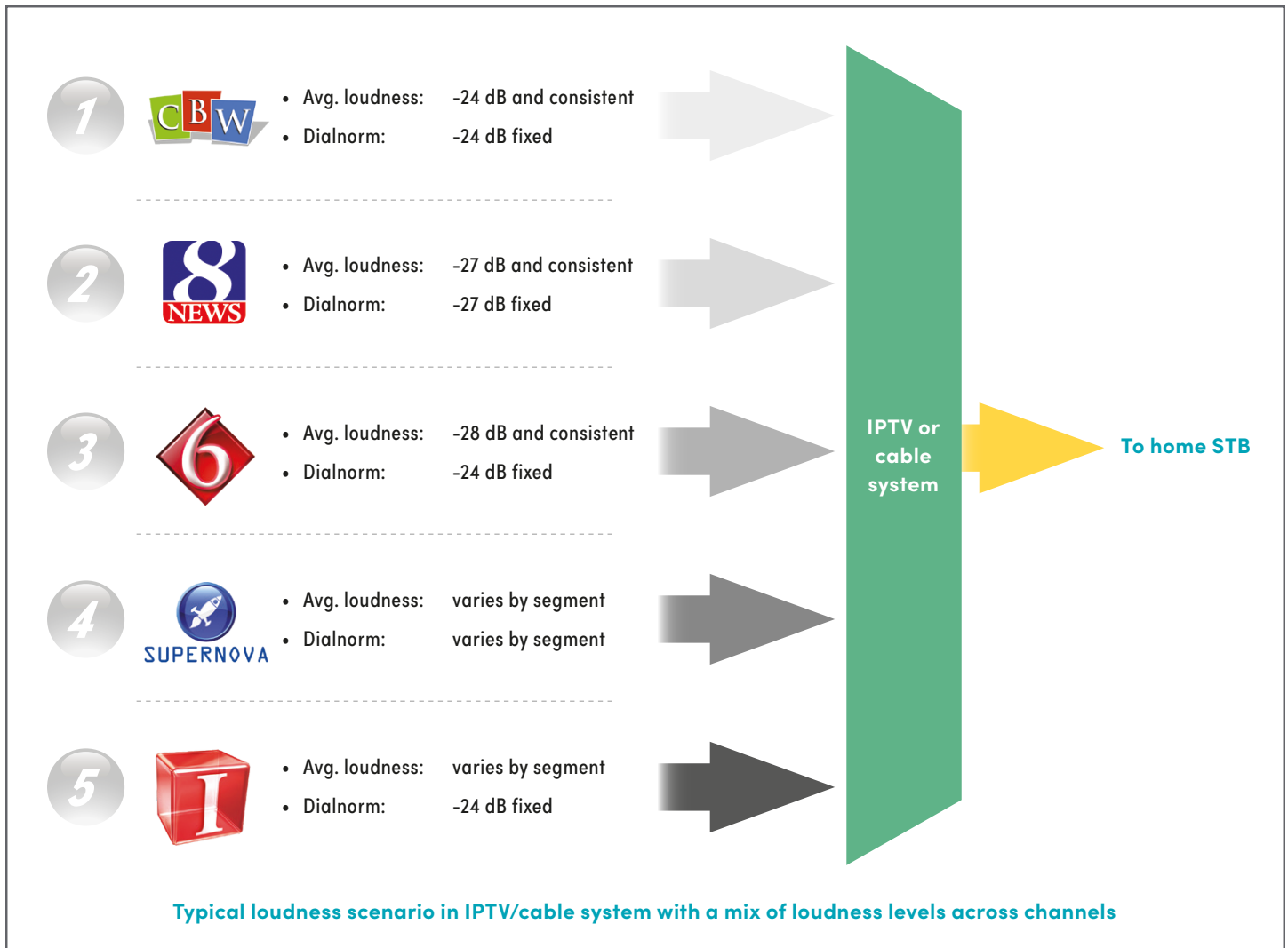



## Specifications

### Quick ALC Comparison Table



	ALC with Linear Acoustic Processing	ALC with Grass Valley Proprietary Processing
Max number of programs	2	8
Max number of channels	8	16
Number of channels/pgm	1, 2 or 6	1, 2, 3, 4, 6 or 8
Audio formats	PCM in / PCM out up to 24 bits at 48 kHz	PCM in / PCM out up to 24 bits at 48 kHz
Technology	AeroMAX, multiband	Wideband
Pulling range	±36 dB	-31 to 18 dB
Limiter range	-6 to 0 dBFS	-20 to dBFS true-peak
Embedded Upmixing option	Yes	No
Loudness Measurement methods	ITU-R BS.1770	ITU-R BS.1770-3
Profile switching (including ALC bypass) via automation/GPI	Yes	Yes
Form factor	Submodule	Software option

## Ordering

### MOD-LA-ALC-2

2-channel ALC licensed by Linear Acoustic

### MOD-LA-ALC-6

6-channel ALC licensed by Linear Acoustic

### MOD-LA-ALC-8

8-channel ALC licensed by Linear Acoustic

### MOD-LA-ALC-2-DUP

2-channel ALC and up mix licensed by Linear Acoustic

### MOD-LA-ALC-6-DUP

6-channel ALC and up mix licensed by Linear Acoustic

### MOD-LA-ALC-8-DUP

8-channel ALC and up mix licensed by Linear Acoustic

### ALC options for XVP-3901 up/down/crossconverter host module\*

#### XVP-3901-OPT-ALC-2

2-channel on-board ALC option by Grass Valley

#### XVP-3901-OPT-ALC-6

6-channel on-board ALC option by Grass Valley

#### XVP-3901-OPT-ALC-8

8-channel on-board ALC option by Grass Valley

#### XVP-3901-OPT-ALC-16

16-channel on-board ALC option by Grass Valley

### ALC options for EAP-3901 embedded audio processor\*

#### EAP-3901-OPT-ALC-2

2-channel on-board ALC option by Grass Valley

#### EAP-3901-OPT-ALC-6

6-channel on-board ALC option by Grass Valley

#### EAP-3901-OPT-ALC-8

8-channel on-board ALC option by Grass Valley

#### EAP-3901-OPT-ALC-16

16-channel on-board ALC option by Grass Valley

### ALC options for HCO-3901 change-over

#### HCO-3901-OPT-ALC-2

2-channel on-board ALC option by Grass Valley

#### HCO-3901-OPT-ALC-6

6-channel on-board ALC option by Grass Valley

#### HCO-3901-OPT-ALC-8

8-channel on-board ALC option by Grass Valley

#### HCO-3901-OPT-ALC-16

16-channel on-board ALC option by Grass Valley

### MOD-LA-DUP-701

Upmixing using Linear Acoustic Technology upMAX

\* If upmixing is required, it can be done on separate sub-module.

This product may be protected by one or more patents. For further information, please visit: [www.grassvalley.com/patents](http://www.grassvalley.com/patents)

DS-PUB-3-0351A-EN

Grass Valley®, GV®, GV Grass Valley®, and the Grass Valley logo are trademarks or registered trademarks of Grass Valley USA, LLC, or its affiliated companies in the United States and other jurisdictions. Grass Valley products listed above are trademarks or registered trademarks of Grass Valley USA, LLC or its affiliated companies, and other parties may also have trademark rights in other terms used herein. Copyright © 2020, 2023 Grass Valley Canada. All rights reserved. Specifications subject to change without notice.

[www.grassvalley.com](http://www.grassvalley.com) Join the Conversation at GrassValleyLive on [Facebook](#), [Twitter](#), [YouTube](#) and Grass Valley on [LinkedIn](#)